

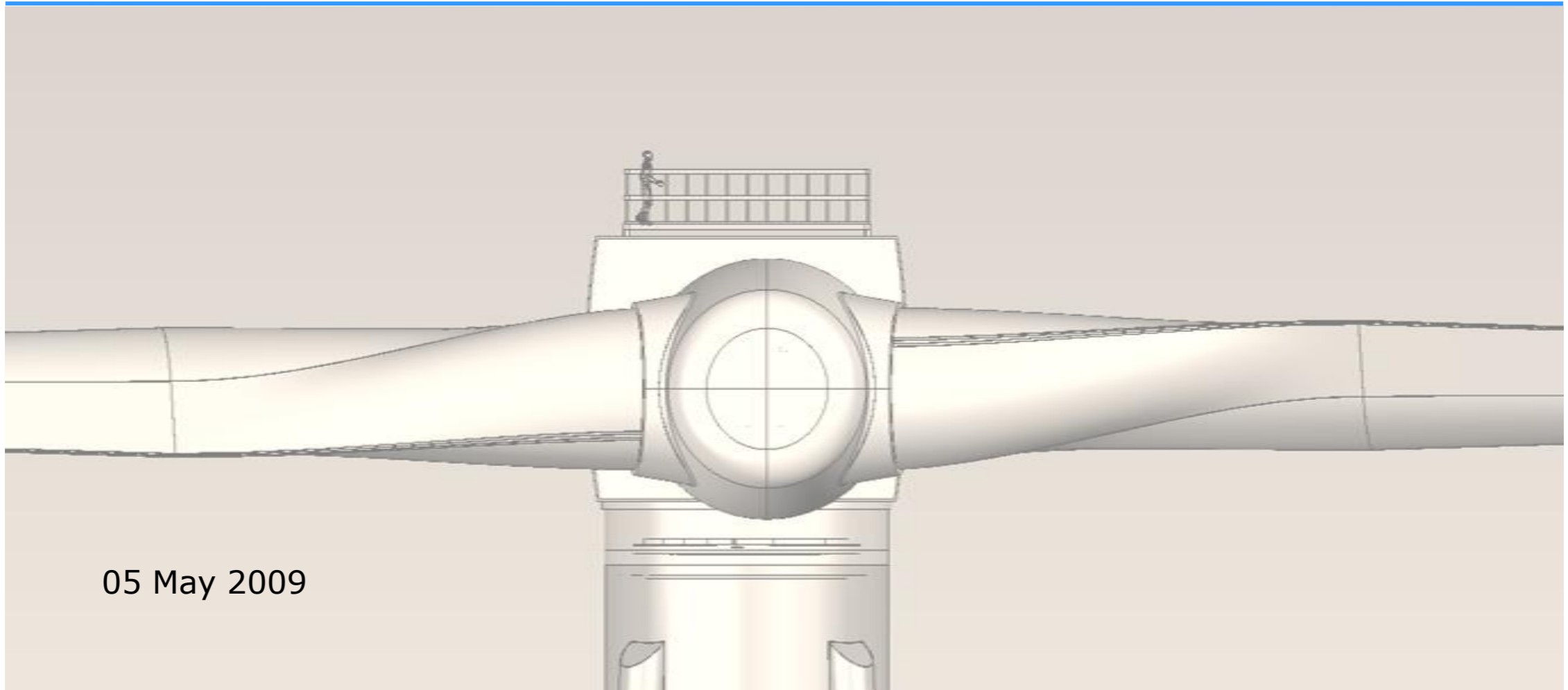

Cleantech forum Copenhagen 2009



05 May 2009

2-B Energy

Background

- 2-B was founded early 2007 by M. Jakobsson and H. Peels
- 2-B team has extensive experience in wind energy (GE/Enron/Shell/Siemens)
- Investors in 2-B: Mainstreamrp/P. Mouratoglou/Truffle

Goals

- Design new offshore wind power plant with significant lower COE
- Aim for large scale projects further out to sea
- First prototype to be installed 2010
- Series production start 2012/2013

2-B Principles for CoE reduction

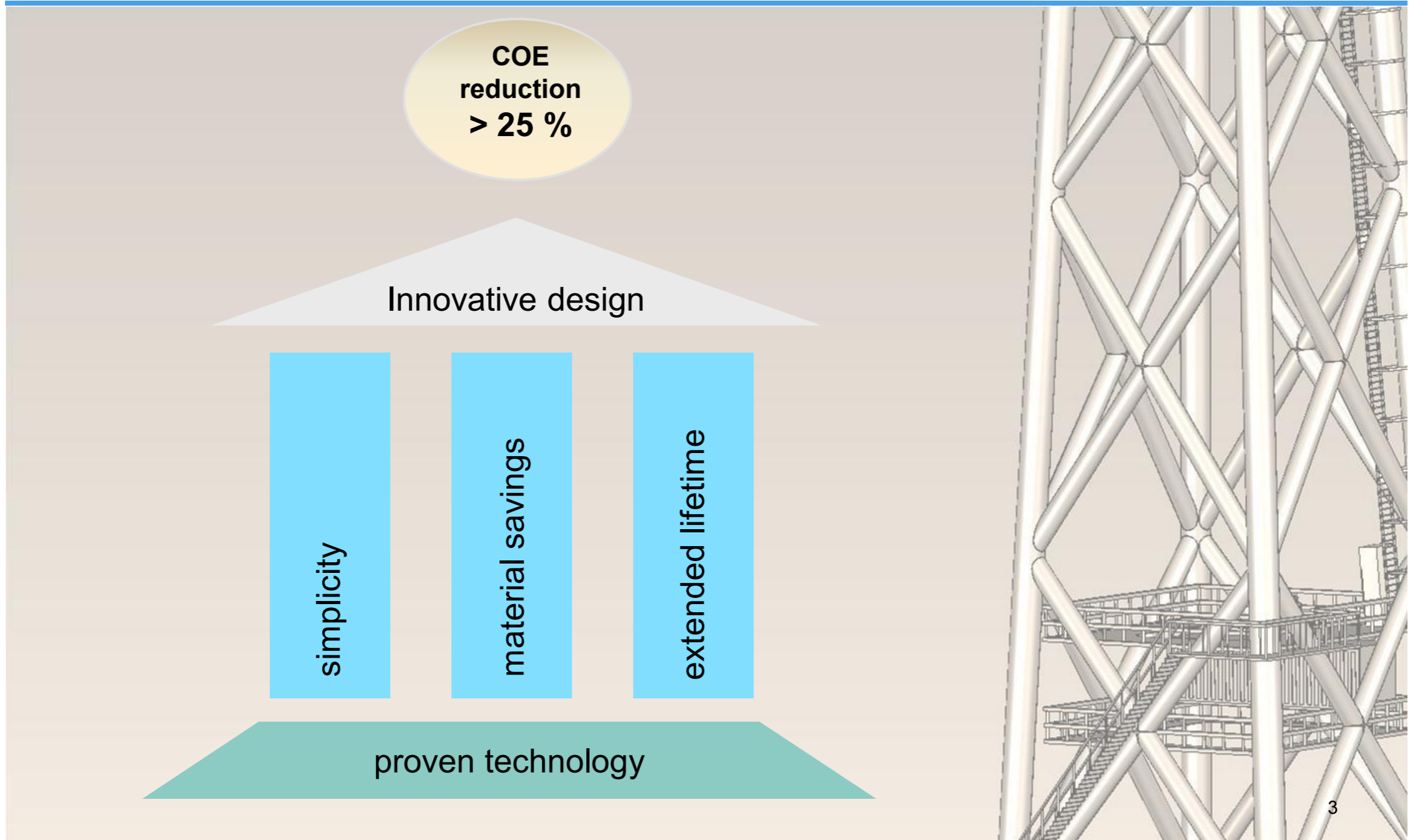

2-B – Design

- 130 m diameter rotor
- 6 MW generator
- Gear driven
- Full jacket structure



- Lowest weight/rotor swept area
- Deep water friendly

